

# Videotek<sup>®</sup> QuIC<sup>™</sup> Media Analysis Server



VIDEOTEK<sup>®</sup> QUIC<sup>™</sup>

The difference between television production 20 years ago and the way broadcasters are doing things today is like night and day. From the initial camera shot to the display in the consumer's living room, production is now being done in an all-digital environment. Compressed digital content is stored as large media files on server networks and produced in a wide variety of file formats, standards and compression algorithms. In such a dynamic setting, quality control has never been more important. Operators are under tremendous pressure to guarantee the integrity of digital files before playout. Today's viewers expect to have the highest quality content delivered to their homes.

## Videotek® QuiC™

The Videotek QuiC media analysis server is a fully automated test and measurement platform that analyzes technical conformance of compressed files residing on servers and storage networks before content is distributed. QuiC supports the quality assurance (QA) workflow by providing adjustable alarm thresholds for each analysis parameter used. Each configurable quality parameter in QuiC determines whether ingested or transferred content is acceptable or unacceptable. QuiC can be operated manually using an intuitive graphical user interface or automatically using a "drop box" or file folder feature to place content into the analysis queue.

## QuiC is Quick.

With the QuiC media analysis server, compressed files are analyzed faster than real time. QuiC uses the Microsoft Windows® XP operating system in conjunction with dedicated measurement hardware modules to perform file processing — five times faster than real time for standard-definition (SD) content and two times faster than real time for high-definition (HD) content.

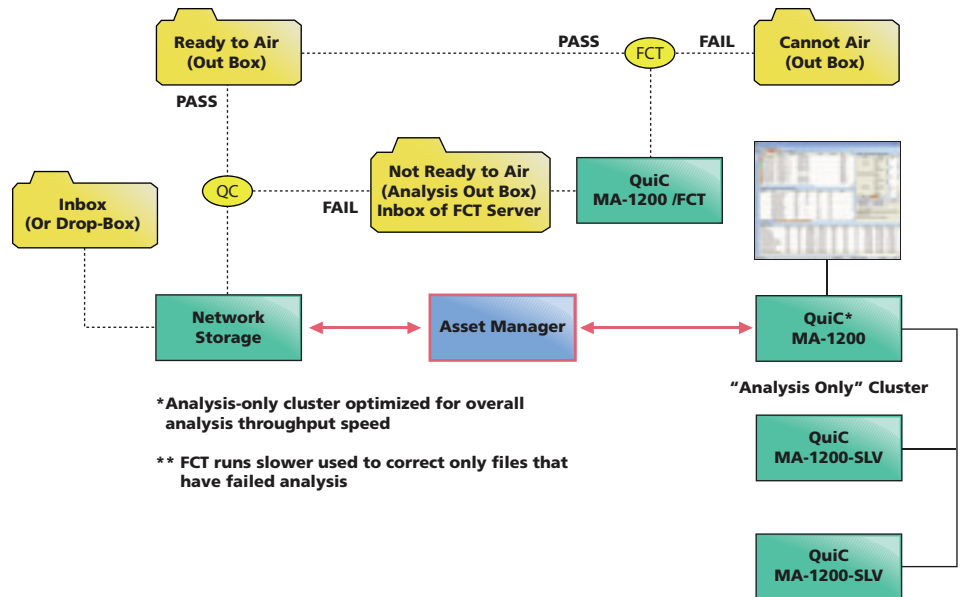

Figure 1. QuiC with Second Pass FCT

## QuiC is Flexible.

The configurable nature of the QuiC server makes this platform well-suited to a variety of television production environments. QuiC is designed for use in any workflow setting, from production to broadcast operations to satellite and cable distribution networks. The QuiC media analysis server easily integrates with and complements the following platforms:

- Ingest servers — QuiC can analyze content at the start of the workflow by evaluating content provided by news operations and program providers.
- Playout servers — Prior to broadcast, QuiC can be used to recheck program content before airing, or to recheck multiple versions of promotional content that will be sent out to other facilities for broadcast.
- Content archiving systems — QuiC can be used to check the quality of the transferred archived library content before the Master is destroyed.

## QuiC is Smart.

In addition to analyzing and reporting on decoded audio and video, QuiC has the capability of correcting identified defects found during the QA process. The correction tools in QuiC include the video legalizer, video proc amplifier and audio processing.

Utilizing video legalization technology, QuiC corrects out-of-spec baseband audio and video content, without requiring the file to be returned to the content provider for re-editing. The video legalizer works with HD/SD native clips, composite clips and RGB clips. QuiC can also operate in a "correction only" mode. The video proc amplifier is used to control overall gain, luma gain, chroma gain and hue.

Audio processing correction includes the following correction utilities: peak limiter, random noise reduction, noise gate, dynamic range compressor, audio level control, click and pop removal and hum elimination. The audio and video correction process is quite fast — SD content can be corrected at more than twice the speed of real time, and the speed of HD correction approaches real time.

# QuiC

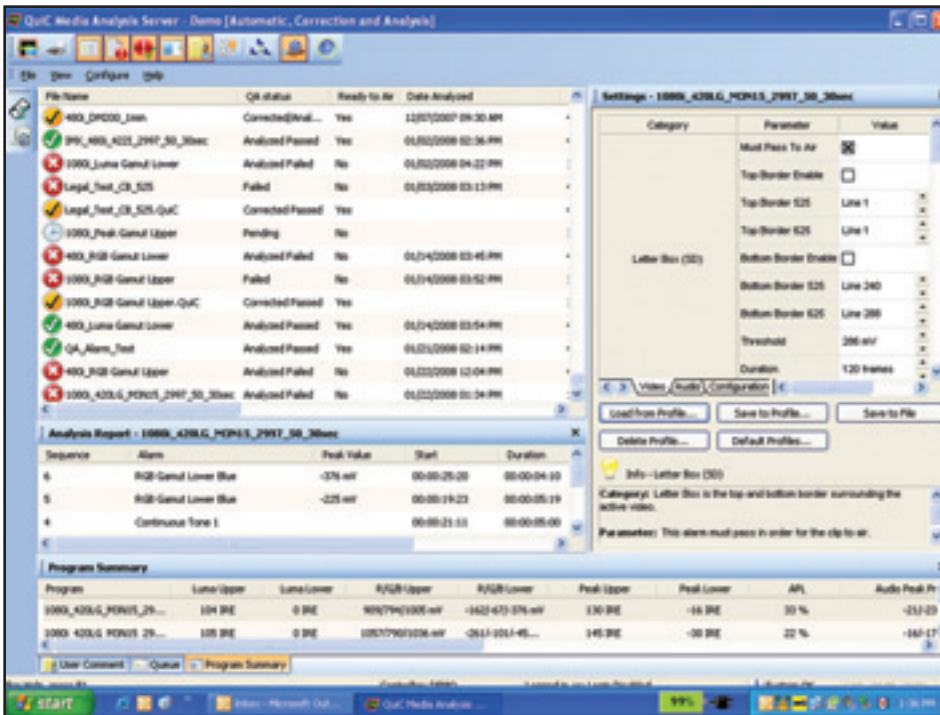

Figure 2. QuiC Graphical User Interface screen

The QuiC advanced Seek to Alarm playout feature enables operators to access files from the mass storage servers, and the file content can be copied to QuiC — where it can easily be viewed and controlled through a convenient Scrub controller. Alarmed frames are referenced to time code, which is displayed on a timeline. The Seek to Alarm playout feature provides full-resolution decoded video and high-quality audio outputs for the operator’s critical evaluation.

Broadcasters can conveniently monitor quality for all commercial spots during ingest, reducing lost revenue due to “make goods.” Since QuiC operates at speeds faster than real time, even rush jobs can be quality controlled prior to air.

## QuiC is Scalable.

You’ll be prepared for the future because the QuiC media analysis server is completely scalable. As your quality analysis needs expand, QuiC can be scaled accordingly to

accommodate increased throughput requirements. Multi-server configuration is made possible through scalable parallel processing (QuiC MA-1200 SLV options). This allows QuiC to meet any network’s quality control requirements by reducing throughput time. As an example, 20 hours of SD content can be processed in just one hour with a QuiC controller and three slave units.

## QuiC is Feature Rich.

QuiC takes audio and video content quality analysis to a new level with other powerful features, such as:

- **Sophisticated Logging and Reporting**
  - Analysis results are logged and written into metadata.
  - A comma separated values (.csv) file by the same name is automatically created.
  - Alarm log reports measured values, specifying time code or non-conforming frame number.

- Reporting on passed/failed criteria and “ready to air” and “not ready to air” status.

- **Pixel-by-Pixel Content Analysis**  
QuiC examines content on the decoded level.
- **Multiple Software Codec Support**  
As video codecs become available, they can be implemented in QuiC without additional hardware.
- **Multiple File Format Support**  
QuiC supports file analysis in multiple file formats, including MPEG-2, IMX50/CBG (Constrained Bytes Per GOP), DV25, Sony XHDCAM HD, AVID DNxHD (8-bit), H.264/AVC and AVC-Intra (10-bit).
- **Content Quality Evaluation**
  - Freeze detect and field detect
  - Color bar detect and blurriness (full field or SMPTE bars)
  - Blockiness
- **Common API for System Integration**  
The common API (application program interface) in QuiC allows for interaction with external software, such as digital asset management. It also provides an easy integration path to the Harris® Media Spy application.
- **Easy Interface to the Harris NEXIO® Server and Other Major Servers**  
QuiC easily connects to the NEXIO server via GIG-E interface. The MA-1200 and MA-1250 interface to all major servers and work with MXF, QuickTime and LXF.
- **Easy-to-Use Graphical User Interface**  
The graphical user interface in QuiC makes it a snap to configure the system, and establish baseband (video and audio alarms) and file attribute (encoding and timing) analysis parameters.
- **Picture Quality Analysis**  
QuiC offers robust picture quality analysis, providing features such as quantization (blocking), color bar detect, blurriness, freeze detect and field order detect.

- **E-mail Notification**  
Automatically notifies operator when file fails to process
- **Time Code Detection**  
Detects SMPTE-formatted time code data; works with MXF, GXF or MOV files
- **Closed-Captioning (CC) Detection**  
Detects CC on line 21 and also includes “closed captioning change detect”; alerts operator when thresholds have been exceeded
- **Multi-Box**  
The multi-box feature allows QuiC to provide analysis from external drop boxes (folders) provided in any server network that permits Windows®-compatible folders. This enhancement provides a configuration wizard that can create rules for external drop folders. Rules include default analysis profiles and priorities per folder. Profile association allows individual folders to be used to analyze files according to specific criteria. For example, one folder may be used for ad content that is analyzed for detailed loudness and video parameters, while another folder may be used for news content that only needs to be checked for encoding artifacts and presence of color-bar, freezes or black frames during programs.

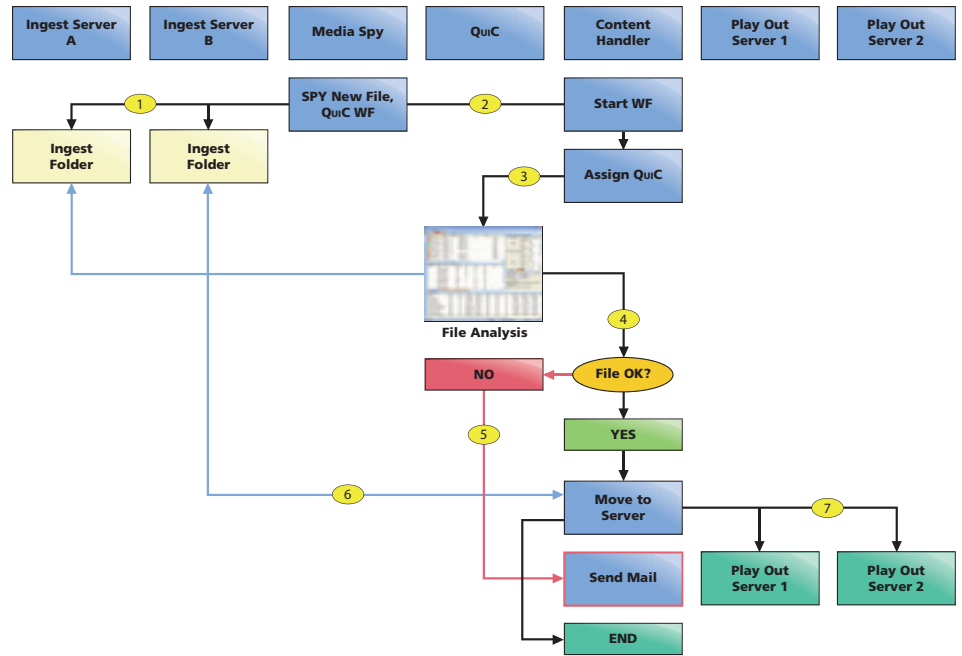

Figure 3. QuiC Integration to Invenio® Motion

You also can build new workflows using the QuiC system's box feature. You can move files from the "failed outbox" of one analyzer to the "auto-correct" inbox of a second analyzer automatically, without third-party media handler intervention. This feature allows QuiC to automatically analyze, report the results of passed content, and move the files to a correction server that may correct video level, audio level or loudness attributes of the content — without manual intervention. Corrected QuiC files can then be moved to any designated outbox — with or without the .QuiC extension — enabling compatibility with common traffic and automation systems.

## Optional QuiC Features

### Loudness Correction

QuiC provides loudness evaluation based on the ITU-R BS.1770 standard and TC Electronic® technology, and examines audio content for “center of gravity” and “consistency” in loudness parameters. In addition to loudness monitoring capabilities, QuiC also can provide tools for the correction of loudness errors. With loudness correction, audio levels can now be adjusted to an acceptable value per the ITU-R BS.1770 standard.

# QuIC

## A/V Playout

QuIC also provides A/V playout as a standard or optional feature on all media analysis servers.\* This powerful function allows you to free up expensive server playout channels. QuIC A/V playout provides a way to view alarm faults on a Videotek waveform/vector\*\* scope — direct from the media analysis server.

\* A/V playout is standard on the MA-1250 system and MA-1200 series QuIC servers.

\*\* Videotek waveform/vector scope optional

## Combining QuIC and NEXIO

When coupled with the NEXIO server, QuIC delivers operational efficiencies that can't be matched by any other digital media management system. QuIC can be added easily to your NEXIO server through one simple Ethernet connection. You get the combined power of the servers because QuIC automatically reads the NEXIO MediaBase. All files to be tested are copied via FTP directly from the NEXIO server.

The NEXIO server sets a flag that allows a file to be placed automatically in the analysis queue upon ingest or change (edit). This automated functionality provides for unattended queuing of files to QuIC, greatly increasing the system's usefulness. Following analysis of a media file, QuIC

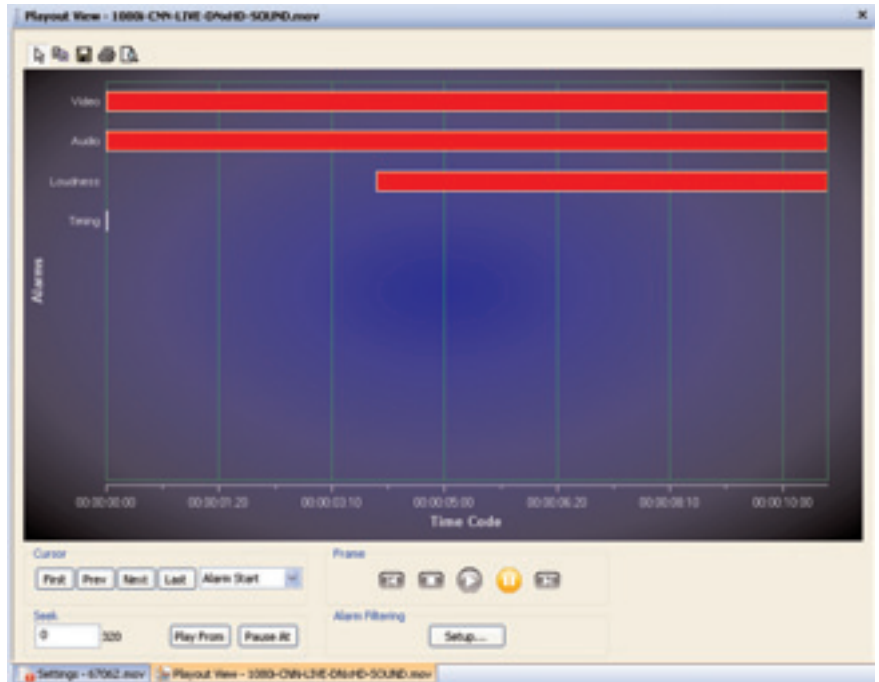

Figure 4. QuIC Playout View

tracks the file's status and creates a summary of test results. This information is then encapsulated in the file's LXF wrapper. This information can be viewed in an easy-to-understand summary screen by extracting data from the LXF at any time. When used with a NEXIO server, the file header is flagged as "Ready for Air" or "Not Ready for Air" for automatic integration. Additionally, the analysis summary is written to a common .csv file for integration to common databases.

QuIC is the complete solution for all your media analysis requirements. Moreover, with the ability to provide file correction tools, QuIC allows you to correct files that may be out of compliance with quality measures. QuIC is also a natural tie-in to the Harris automation workflow, allowing Invenio® Motion asset management software to direct files to QuIC to automate the QC process as part of a complete, unattended 24/7 workflow.

Thanks to an open API, the QuIC system works with many popular servers and automation systems. In addition to the NEXIO server, QuIC models MA-1200 and MA-1250 interface to all major servers and wrappers including MXF, QuickTime and LXF. Please contact Harris for specific configuration information to support your workflow needs.

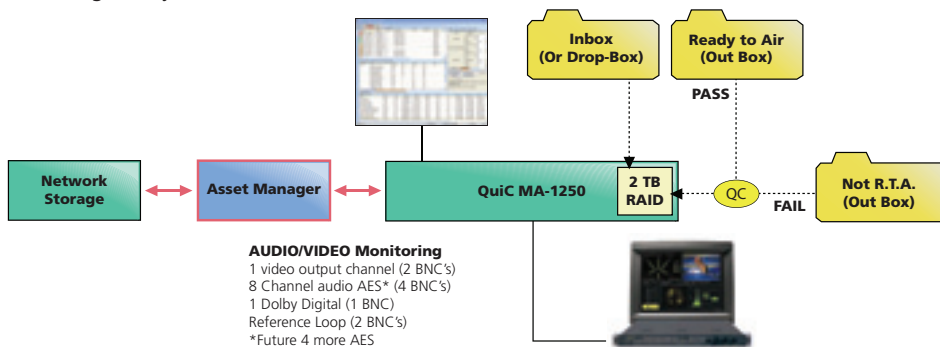

Figure 5. QuIC with Internal Drop Box and Storage

## Ordering Guide

Model Number	Description	Software Codec
MA-1200-01	QuiC with LXF, MXF, GXF and QuickTime wrapper (includes transport stream, program stream and XDCAM)	MPEG-2
MA-1200-02	QuiC with LXF, MXF, GXF and QuickTime wrapper	DV
MA-1200-03	QuiC with LXF, MXF, GXF and QuickTime wrapper	Avid DNxHD®
MA-1200-04	QuiC with LXF, MXF, GXF and QuickTime wrapper	MPEG-4
MA-1200-SLV-01	QuiC slave server (includes transport stream, program stream and XDCAM)	MPEG-2
MA-1200-SLV-02	QuiC slave server	DV
MA-1200-SLV-03	QuiC slave server	Avid DNxHD®
MA-1200-SLV-04	QuiC slave server	MPEG-4
MA-1250-01*	QuiC with file correction tools and A/V playback (includes transport stream, program stream and XDCAM)	MPEG-2
MA-1250-02*	QuiC with file correction tools and A/V playback	DV
MA-1250-03*	QuiC with file correction tools and A/V playback	Avid DNxHD®
MA-1250-04*	QuiC with file correction tools and A/V playback	MPEG-4
MA-1250-05*	QuiC with file correction tools and A/V playback	AVC-INTRA

\* MA-1250 supports all wrappers offered with the MA-1200.

### Upgrade Kit

MA-OUT-U	Factory upgrade kit converts MA-1100 and MA-1200 to MA-1250, includes A/V playback, does not include file correction tools
MA-OUT-F	Field upgrade kit converts MA-1100 and MA-1200 to MA-1250, includes A/V playback, does not include file correction tools

### Options

MA-REM-VS	Remote View Station
MA-OPT-FCT	Software package adding file correction tools
MA-SFTW-MAINT	Adds one year to software package, includes software upgrades and enhancements — 7% of list price
MA-OPT-LL	Loudness evaluation per ITU BS.1770 Standard, metadata for center of gravity and consistency analysis per media analysis server

### Codec

MA-SWC-MPEG-2	MPEG-2
MA-SWC-DV	DV
MA-SWC-DNX	Avid DNxHD®
MA-SWC-MPEG-4	MPEG-4 (H.264)
MA-SWC-AVC-I	AVC-INTRA

## Specifications

### VIDEO

HD Formats	1080i @ 29.97, 25.00 f/s; 720p @ 59.94, 50.00 f/s
SD Formats	480i @ 29.97 f/s; 576i @ 25.00 f/s; 512i @ 29.97 f/s; 608i @ 25.00 f/s
Aspect Ratios	16:9 (HD), 4:3 (SD)

### AUDIO

Channels and Formats	8 channels of PCM audio
Processing and Sample Rate	16-, 20- or 24-bit, 48 kHz

### VIDEO ALARM CAPABILITIES

- Color Bar Detect
- Blurriness
- Blockiness (macro blocking)
- Luma Gamut Low or High
- Letter Box (SD)
- Picture Shift (asymmetrical blanking)
- Encoding Standard Match
- MPEG Level Match
- GOP Length
- Frame Size
- File Length
- Black Leader
- Closed Captioning Detection
- Freeze Detect
- Top Field/Bottom Field Detect
- RGB Gamut Low or High
- Composite Peak Low or High
- Pillar Box (HD)
- Average Picture Level (APL)- Low or High
- MPEG Profile Match
- GOP Structure
- Frame Rate
- Aspect Ratio
- Black Trailer
- Black Frames during Program
- Time Code Detection

### AUDIO ALARM CAPABILITIES

- Audio/Video Mismatch
- MPEG PCM 48 kHz
- Audio Phase
- Continuous Tone
- Low Audio
- Dolby® Format Change
- 8 Channels Audio
- Peak Audio
- Loss of Sound
- Mute
- High Average Audio

### LOUDNESS CAPABILITIES (ITU-R BS.1770)

- Average Loudness (Center Of Gravity)
- Consistency Loudness Measure

### VIDEO DATA RATE

HD Decoding	MPEG-2 long GOP 4:2:0 or 4:2:2 profile up to 100 Mb/s MPEG-2 I-frame at 4:2:0 or 4:2:2 profile up to 100 Mb/s XDCAM-HD 4:2:0 profile at 35/25/18 Mb/s XDCAM-HD 4:2:2 profile at 50 Mb/s AVID DNxHD DVCPROHD 4:2:2 profile at 100 Mb/s AVC-I 50 I-frame 4:2:0 at 50 Mb/s AVC-I 100 I-frame 4:2:2 at 100 Mb/s H.264/AVC long GOP 4:2:0 profile up to 50 Mb/s
SD Decoding	AVC-I 100 I-frame 4:2:2 at 100 Mb/s MPEG-2 long GOP 4:2:0 profile up to 15 Mb/s MPEG-2 long GOP 4:2:2 profile up to 50 Mb/s MPEG-2 I-frame 4:2:0 or 4:2:2 profile up to 50 Mb/s IMX MPEG-2 CBG 30, 40, and 50 Mb/s DV25 4:1:1 (525/60) or 4:2:0 (625/50) profile at 25 Mb/s DVCAM 4:1:1 (525/60) or 4:2:0 (625/50) profile at 25 Mb/s DVCPRO 4:1:1 (525/60) or 4:2:0 (625/50) profile at 25 Mb/s DVCPRO50 4:2:2 profile at 50 Mb/s H.264/AVC long GOP 4:2:0 profile up to 10 Mb/s

### STORAGE

Storage Options	Internal 500 GB (x2) drives
-----------------	-----------------------------

### RAID REDUNDANCY

RAID Protection Schemes	Single drive mirroring (RAID 1 failure protection)
-------------------------	--

### PHYSICAL SPECIFICATIONS

Height	5.25 in.
Width	19 in.
Length	27.00 in. from the rack ears to the back panel 28.00 in. from the front of the bezel to the back panel
Weight	63 lbs.

### POWER SUPPLY

- Redundant dual load-sharing
- AC115 to 120/200 to 240 V, auto-sensing
- 60/50 Hz
- 600 W

## Video Decoding and Data Rates

MPEG-2		
<b>I-Frame 4:2:2</b>	<b>Frame Rate</b>	<b>Mb/s</b>
480i	29.97	50
576i	25.00	50
720p	59.94, 50.00	100
1080i	29.97, 25.00	100
<b>Long GOP 4:2:2</b>	<b>Frame Rate</b>	<b>Mb/s</b>
480i	29.97	50
576i	25.00	50
720p	59.94, 50.00	100
1080i	29.97, 25.00	100
<b>Long GOP 4:2:0</b>	<b>Frame Rate</b>	<b>Mb/s</b>
480i	29.97	15
576i	25.00	15
720p	59.94, 50.00	100
1080i	29.97, 25.00	100
IMX50/CBG (Constrained Bytes Per GOP)		
<b>I-Frame 4:2:2</b>	<b>Frame Rate</b>	<b>Mb/s</b>
480i	29.97	50
512i	29.97	50
576i	29.97	50
608i	25.00	50
DV25		
<b>I-Frame 4:1:1</b>	<b>Frame Rate</b>	<b>Mb/s</b>
480i	29.97	25 (fixed)
<b>I-Frame 4:2:0 DVCAM</b>	<b>Frame Rate</b>	<b>Mb/s</b>
576i	25.00	25 (fixed)
DVCPRO		
<b>I-Frame 4:2:2</b>	<b>Frame Rate</b>	<b>Mb/s</b>
480i	29.97	50 (fixed)
576i	25.00	50 (fixed)
DVCPRO50		
<b>I-Frame 4:2:2</b>	<b>Frame Rate</b>	<b>Mb/s</b>
480i	29.97	50 (fixed)
576i	25.00	50 (fixed)
DVCPROHD		
<b>I-Frame 4:2:2</b>	<b>Frame Rate</b>	<b>Mb/s</b>
720p	59.94, 50.00	100 (fixed)
1080i	29.97, 25.00	100 (fixed)
SONY XDCAM HD		
<b>I-Frame 4:2:0</b>	<b>Frame Rate</b>	<b>Mb/s</b>
1440x1080	29.97	50/35/25/18
<b>I-Frame 4:2:2</b>	<b>Frame Rate</b>	<b>Mb/s</b>
1920x1080	29.97	50
1280x720	59.94	50
AVID DNxHD 8-Bit		
<b>I-Frame 4:2:0</b>	<b>Frame Rate</b>	<b>Mb/s</b>
1920x1080	29.97	220/145/50/36
H.264/AVC		
<b>Long GOP 4:2:0</b>	<b>Frame Rate</b>	<b>Mb/s</b>
480i	29.97	10
576i	25.00	10
720p	59.94, 50.00	50
1080i	29.97, 25.00	50
AVC-I 50		
<b>I-Frame 4:2:0 (10-bit color)</b>	<b>Frame Rate</b>	<b>Mb/s</b>
1440x1080	23.98, 25, 29.97, 50, 50.94	50
960x720	23.98, 25, 29.97, 50, 50.94	50
AVC-I 100		
<b>I-Frame 4:2:2 (10-bit color)</b>	<b>Frame Rate</b>	<b>Mb/s</b>
1920x1080	23.98, 25, 29.97, 50, 50.94	100
1280x720	23.98, 25, 29.97, 50, 50.94	100

## ONE Company for Workflow Solutions Throughout the Media Chain

Harris is the ONE company delivering interoperable workflow solutions across the entire media delivery chain — providing today's broadcaster with a single, integrated approach to capitalize on the benefits of IT and mobile applications. By providing unparalleled interoperability across our product portfolio, Harris is able to offer customers integrated solutions that improve workflows, save money, enable new revenue streams and provide a migration path to emerging media business models. To meet the evolving needs of broadcast, distribution, government agencies and entertainment businesses, Harris is the ONE answer for change.

## Service And Support

At Harris, we are committed to customer service excellence. It is our goal to provide the highest level of support by applying a simple rule: We take ownership of helping our customers succeed. Our support teams consist of innovative technical experts who support all situations regarding product performance, integration and operational processing. We are adept at providing proven solutions, making workflows better and ensuring reliability of the product and system. At Harris, our experienced and dedicated teams stand ready to help you meet your goals for premium product performance, 100% up-time and reduced maintenance investment.

## Warranty

Because we want to assure you that Harris stands beside its products and system solutions, our products carry a standard set of warranty services, which are competitive with — and in some cases outperform — others in the industry.

## Service Packages

We offer value-add services that allow you to customize the level of services you need in meeting mission-critical performance levels. Our service package options offer many ways to upgrade your standard warranty by choosing the All-Inclusive OnePak, or by selecting individual services from our extensive portfolio. Our service and support advisors can assist in the selection of the individual services that best suit your requirements.

<b>North America</b>	+1 800 231 9673
<b>Caribbean and Latin America</b>	+1 786 437 1960
<b>Europe, Middle East and Africa</b>	+44 (0) 118 964 8200
<b>Asia, Pacific Rim</b>	+852 2776 0628

For more information, please visit [www.broadcast.harris.com/videtok](http://www.broadcast.harris.com/videtok).

Harris is a registered trademark of Harris Corporation. Trademarks and tradenames are the property of their respective companies.



Broadcast Communications Division  
25 Dyas Road | North York, Ontario CANADA M3B 1V7 | Tel: 1 (416) 445-9640  
[www.broadcast.harris.com](http://www.broadcast.harris.com)